

PARÇA KODU PART CODE	PARÇA ADI PART NAME	s ÖLÇÜSÜ (KALINLIK) s MEASURE (THICKNESS)	Malzeme Material	Kaplama Coating
TŞ 2405.40 DP	1 NO KABLO UÇ Ø3.5 =DP=	0.40±0.05	(CuZn30) Pirinç / Brass	—
TŞ 2405.40 RP	1 NO KABLO UÇ Ø3.5 =RP=	0.40±0.05	(CuZn30) Pirinç / Brass	—
TŞ 2405.40 RPK	1 NO KABLO UÇ Ø3.5 =RPK=	0.40±0.05	(CuZn30) Pirinç / Brass	Kalay / Sn (3-5µ)
TŞ 2405.50 DP	1 NO KABLO UÇ Ø3.5 =DP=	0.50±0.05	(CuZn30) Pirinç / Brass	—
TŞ 2405.50 RP	1 NO KABLO UÇ Ø3.5 =RP=	0.50±0.05	(CuZn30) Pirinç / Brass	—
TŞ 2405.50 RPK	1 NO KABLO UÇ Ø3.5 =RPK=	0.50±0.05	(CuZn30) Pirinç / Brass	Kalay / Sn (3-5µ)
TŞ 2405.50 RÇN	1 NO KABLO UÇ Ø3.5 =RÇN=	0.50±0.05	Nikel kaplı çelik / Nickel plated Steel	Nikel / Ni (≥1.5µ)

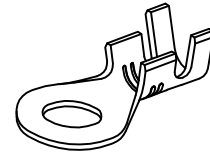

Perspektif  
Perspective

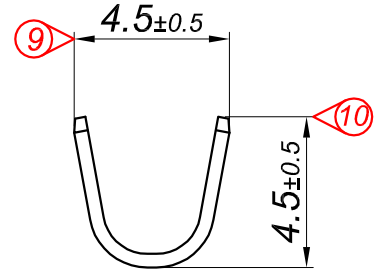
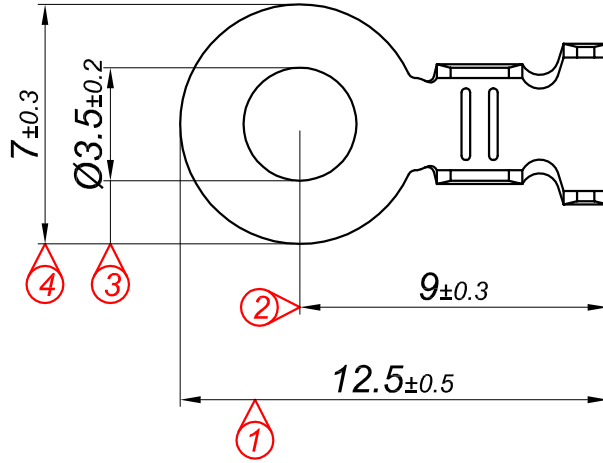
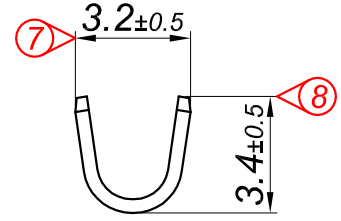
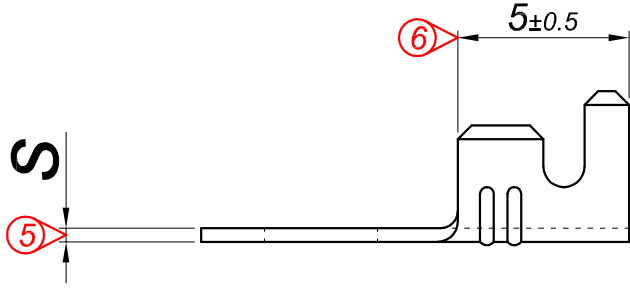
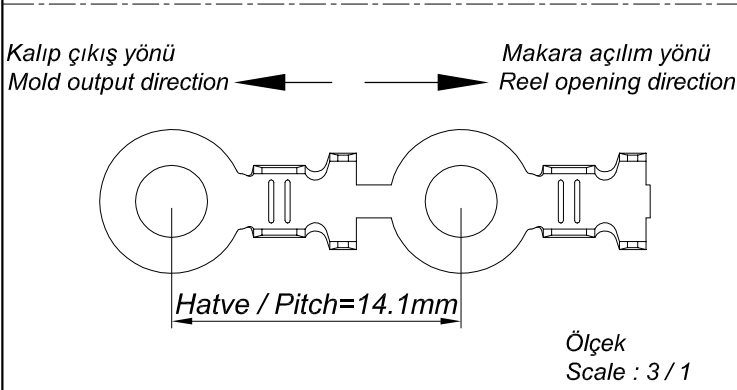

Kablo Kesiti  
Wire Section : 0.50 - 1 mm<sup>2</sup>

Resim üzerinden ölçü almayınız  
do not measure on drawing

Tarih / Date	19.07.2013	İmza /Signature	Ölçek /Scale		
Çizen / Desing	M.Yağcı		5 / 1		
Onay / Approval	S.Gölcük		No	Değişiklik / Revision	Tarih/Date



Parça Adı:  
Part Name  
**1 NO KABLO UÇ Ø3.5**

Parça Kodu:  
Part Code  
**TŞ 2405**